

MECHBADGER®

MECHBADGER



ONE MACHINE... MANY JOBS !

DNA MULTIFUNZIONE

ZERO EMISSIONI

**POTENTE
& AFFIDABILE**

VERSATILE



www.mechbadger.com



MECHBADGER

One machine... many jobs!



MECHBADGER SRL – ONE MACHINE...MANY JOBS!!

MECHBADGER è un'azienda innovativa nata dall'idea di un gruppo di professionisti con una lunga esperienza maturata in aziende leader del settore delle macchine movimento terra; con solide basi in Italia, MECHBADGER nasce come azienda internazionale grazie alle filiali commerciali negli USA e nell'INDIA.

La MISSION di MECHBADGER è quella di creare macchine altamente personalizzabili e tecnologicamente avanzate che possano essere il partner ideale per tutte le applicazioni tipiche e speciali nei lavori edili, agricoli e di manutenzione aerea.

MECHBADGER è anche uno dei principali attori della rivoluzione GREEN, offrendo al mercato anche soluzioni FULL ELECTRIC veramente SOSTENIBILI con un ottimo rapporto qualità/prezzo e bassi costi di gestione.

Grazie ad un giovane team di Ingegneri e Tecnici, MECHBADGER è un'azienda flessibile sempre pronta ad accettare nuove sfide nella creazione di attrezzature innovative e personalizzate per automatizzare anche i processi più complessi ed impegnativi.

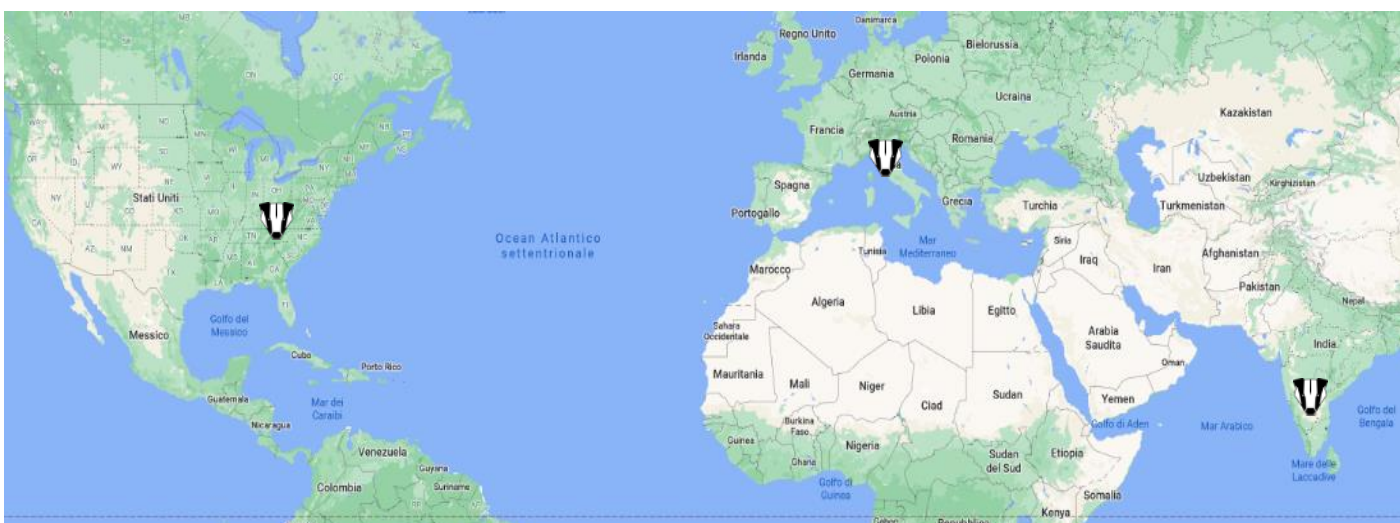



Multi – Purpose Machine 01



MP01 – DNA MULTIFUNZIONE

La macchina multifunzionale MECHBADGER MP01 è stata appositamente pensata, progettata e realizzata per dare a tutti gli operatori del mondo dell'edilizia, dell'agricoltura e del giardinaggio la possibilità di operare veramente con un'unica macchina.

Una macchina dai bassi costi di esercizio, che permette di lavorare al meglio in molte applicazioni specifiche, dallo scavo alla movimentazione dei materiali, dalla pulizia ai lavori di manutenzione in quota, dallo scarico dei materiali alle applicazioni idrauliche più gravose.

L' MP01 è in grado di svolgere moltissimi lavori diversi, grazie al suo sistema unico e BREVETTATO per il collegamento e lo scambio di diverse attrezzature sull'unità di potenza, che permette di passare da una funzione all'altra in soli 5 minuti senza svitare un bullone e senza l'utilizzo di attrezzature e strumenti dedicati.





MP - 01

Piattaforma Aerea

**Loader
Multifunzionale**



Excavator



SISTEMA DI ACCOPPIAMENTO BREVETTATO



Dumper



Mixer



POWER UNIT

ELETTRICO



BENZINA/DIESEL



Modello Motorizzazione	PETROL	DIESEL	FULL ELECTRIC
	HONDA GX390	KOHLER KD15-440	
Peso	540 kg / 1091 Lb	550 kg / 1213 Lb	645 kg / 1423 Lb
Potenza	8.7 kW - 12 Hp	7.5 kW - 10Hp	7 kW
Rpm	3600	3600	2600
Tensione (V)			48 VDC
Capacità batteria			150 Amp/h
On Board STD carica 220V			5 hours
Booster Optional carica 380 V			1.5 hours
Avviamento Motore	Electric	Electric	Electric
Pendenza superabile	70% (35°)	70% (35°)	70% (35°)
Idraulica	2 variable piston pumps + 2 gear pumps	2 variable piston pumps + 2 gear pumps	2 variable piston pumps + 2 gear pumps
Motoriduttori traslazione	Hyd closed circuit with parking brake	Hyd closed circuit with parking brake	Hyd closed circuit with parking brake
Pressione imp.idraulico	150 bar / 2180 psi	150 bar / 2180 psi	150 bar / 2180 psi
Portata imp.idraulico	30 Ltm / 7.93 Gpm	30 Ltm / 7.93 Gpm	30 Ltm / 7.93 Gpm
Forza di Trazione	10003 N	10003 N	10003 N
Velocità	4.5 Kmh / 2.8 mph	4.5 Kmh / 2.8 mph	4.5 Kmh / 2.8 mph



EQUIPMENT

DUMPER



Peso a vuoto

450 Kg / 538 Lb

Capacità di carico

800 kg / 1764 Lb

Volume

0.32 m³ / 0.42 yd³

SAE Volume

0.41 m³ / 0.54 yd³

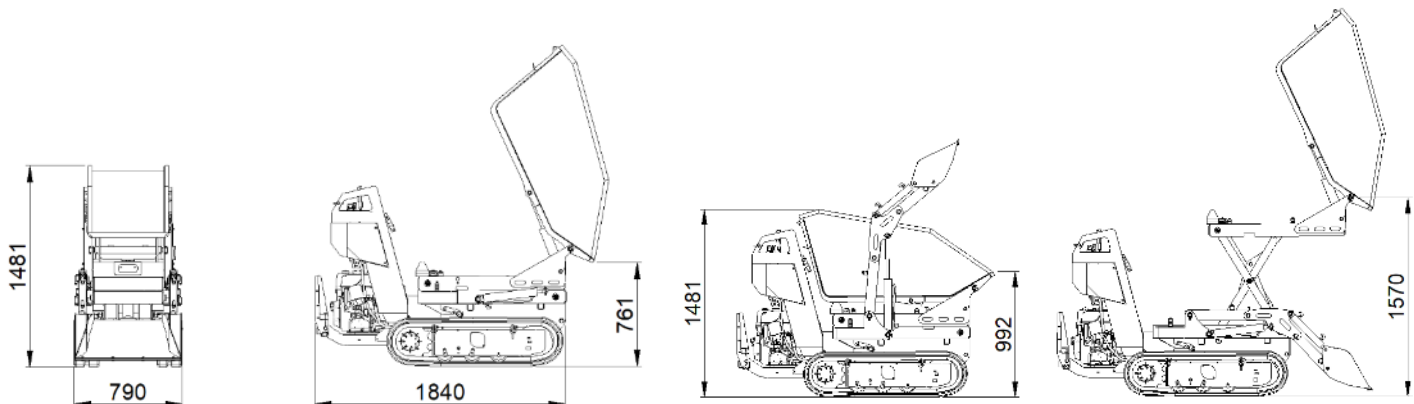



EQUIPMENT

MIXER



Peso a vuoto

530 Kg / 1168 Lb

Volume

220 Lt / 58 Gal

SAE Volume

120 Lt / 32 Gal

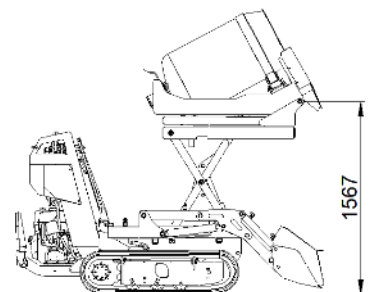
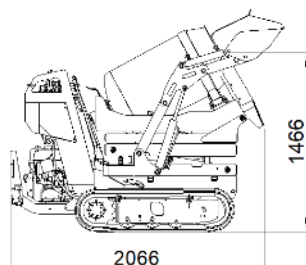
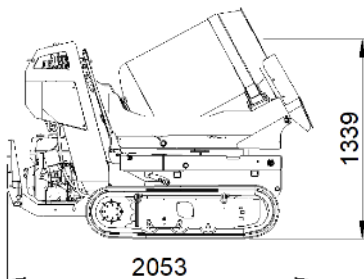
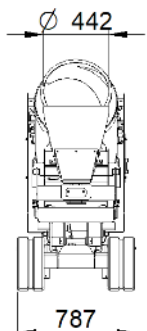



EQUIPMENT

LOADER



Peso a vuoto

719 Kg / 1585 Lb

Capacità di carico

400 Kg / 882 Lb

Altezza di scarico

2200 mm / 7.2 Ft

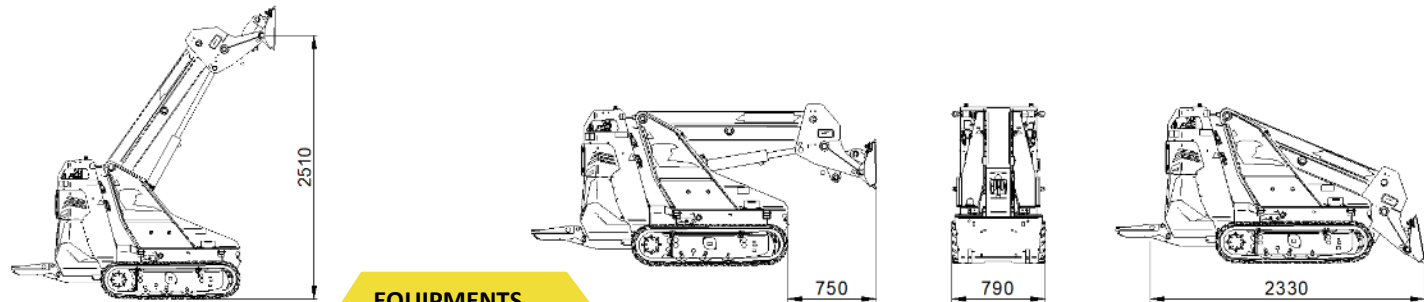

EQUIPMENTS





EQUIPMENT

EXCAVATOR



Peso a vuoto	575 Kg / 1267 Lb
Profondità di scavo	1850 mm / 6 Ft
SAE Profondità di scavo	1590 mm / 5.2 Ft
Forza di strappo	8.8 kN

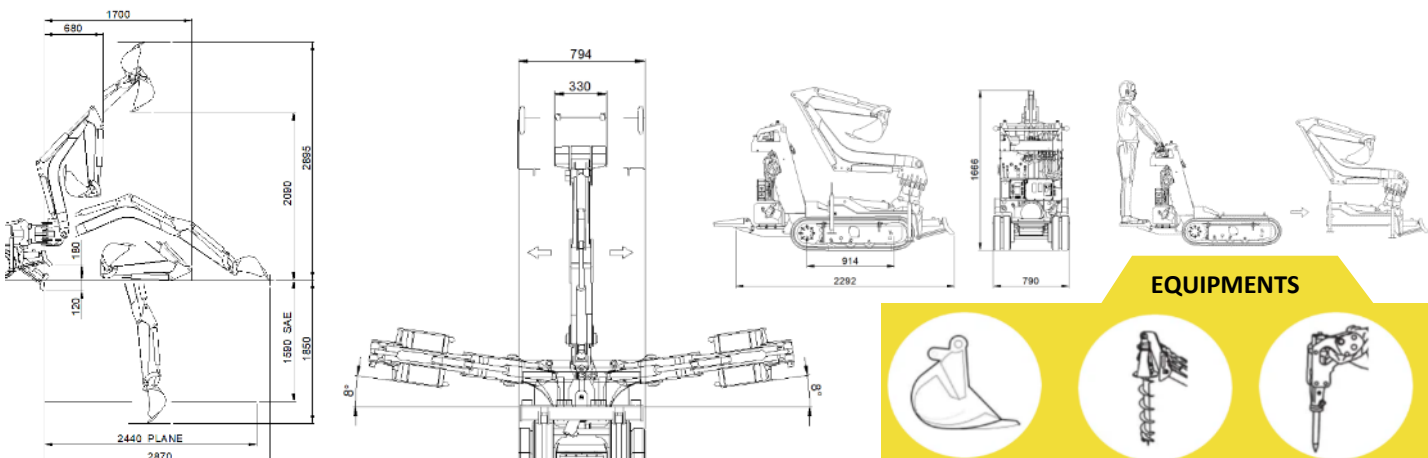

EQUIPMENTS





EQUIPMENT

AERIAL PLATFORM

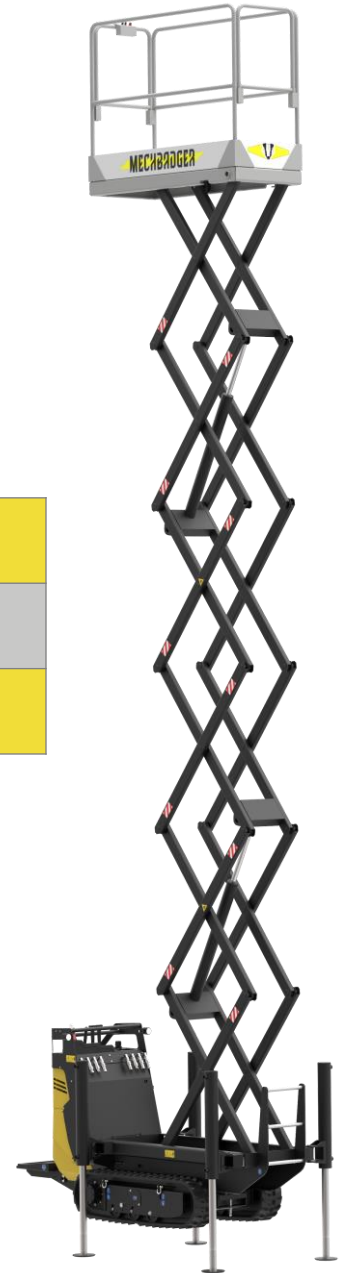

Peso a vuoto

1181 Kg / 2604 Lb

Capacità di carico

250 Kg / 551 Lb

Altezza di lavoro

9200 mm / 30 Ft

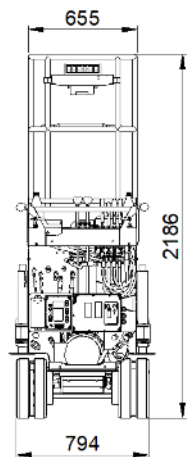
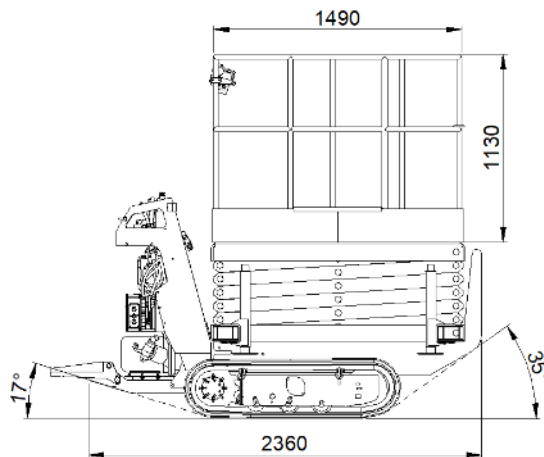
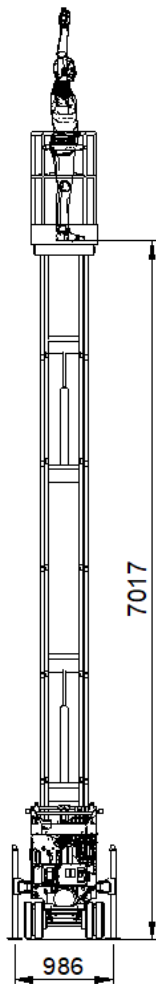
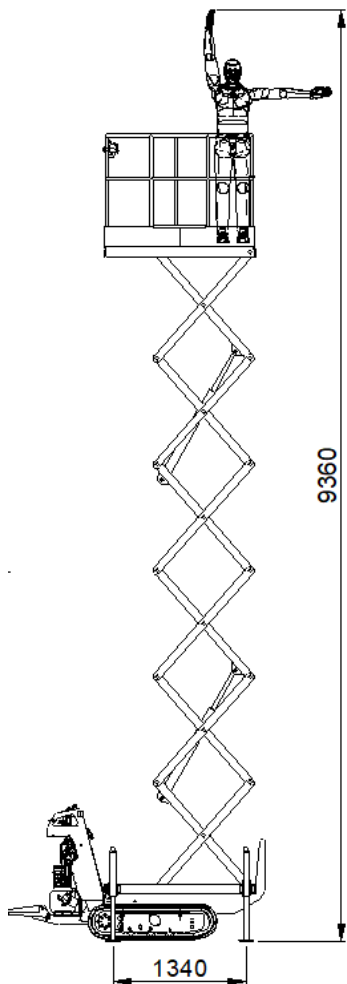



MECHBADGER

CONTATTI

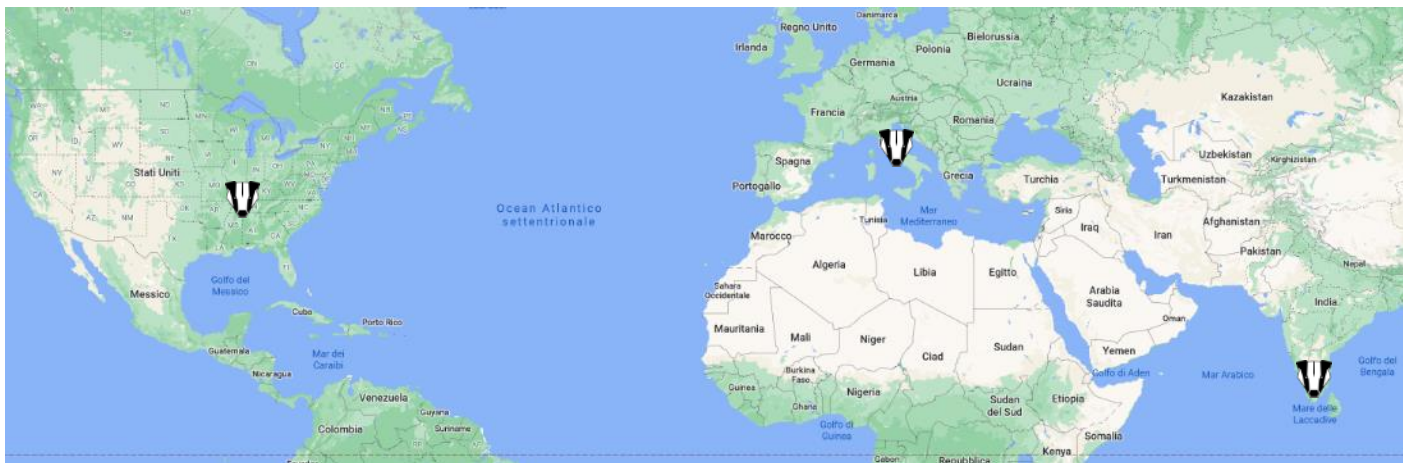

www.mechbadger.com

Mechbadger Europe

Via Cavour, 30,
40026 Imola (BO)
ITALY

MP01

**One machine....
many jobs!**

Mechbadger North America

2288, Gunbarrel 154-264,
Chattanooga 37421 TN
USA

Mechbadger Asia

#214, Athiyur Road,
Kunnathur 638 103, Tamilnadu,
INDIA



info@mechbadger.com